

Instruction Manual for Intelligent Prosthesis Knee Joint NI-C111t

This manual explains the adjustment procedure of the load brake, the replacement procedure of the rubber extension stops and the adjustment when occurs looseness in the knee axis for NI-C111t. As for the handling procedures of the following items, refer to the Instruction Manual for Intelligent Knee Joint (Version: NI-C111) (Document No.81-SS00005).

- Adjusting static alignment
- Fitting the Pylon
- Replace the battery
- Adjusting terminal impact

1. Adjustment procedure of load brake

Adjust the load brake in accordance with the following procedure after completion of the alignment adjustment.

- (1) Let the user (amputee) hold the parallel bars or handrails.
- (2) With the knee slightly bent and the weight of the body applied, adjust the brake force by gradually turning adjusting screw A using the attached exclusive-use hexagonal wrench until the knee will no longer bend.

Note:

- ① Conduct adjustment of the adjusting screw A from the rear of the knee joint (as shown in Figure 1) while the user(amputee) is standing.
 - ② When the adjusting screw A is turned clockwise, the braking effect will reduce, and when it is turned counterclockwise, the braking force will increase.
 - ③ Do not hit the hex wrench against the rod of pneumatic cylinder.
 - ④ The maximum brake effective knee bending angle should be 50 to 60°. However, the user (amputee) may set any required angle less than this.
- (3) After adjusting the brake, walk quickly, walk on a downward slope or walk down stairs if possible, and confirm that the brake is not applied when the tip of toe leaves the floor. If the brake catches, gradually reduce the braking force to achieve correct adjustment.

Remarks: Knee friction is factory set to an optimum condition for intelligent performance. Should readjustment be required, first loosen the set screw using a 2mm wrench, and then gradually turn adjusting screw B to the required setting.

Note:

- ① To increase the friction, turn the adjusting screw B clockwise, and to reduce the friction, turn it counterclockwise.
- ② After setting the correct adjustment, apply adhesive (LOCTITE #243 or equivalent) to the set screw to prevent loosening. (Tightening torque: 180 to 190 N.cm [18 to 19 kg.cm])
- ③ If the friction has been adjusted excessively, the adjusting screw hole in the C-section may be hidden inside the frame and cannot be exposed by bending the knee. To correct this, turn adjusting screw A clockwise to loosen the brake, and the friction will be released allowing the knee to be bent.

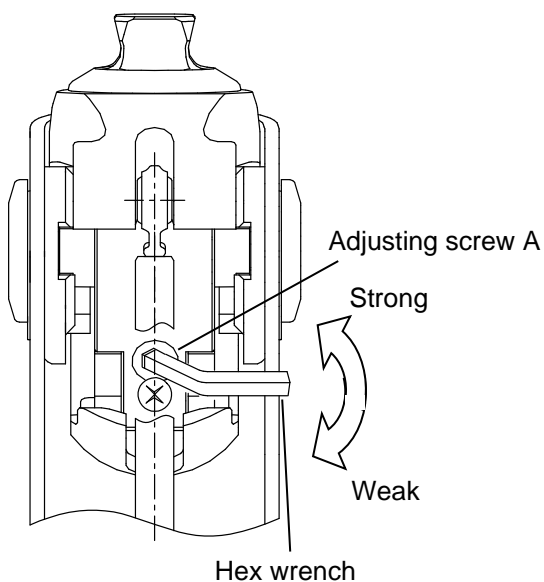

Figure 1: Load brake adjustment procedure

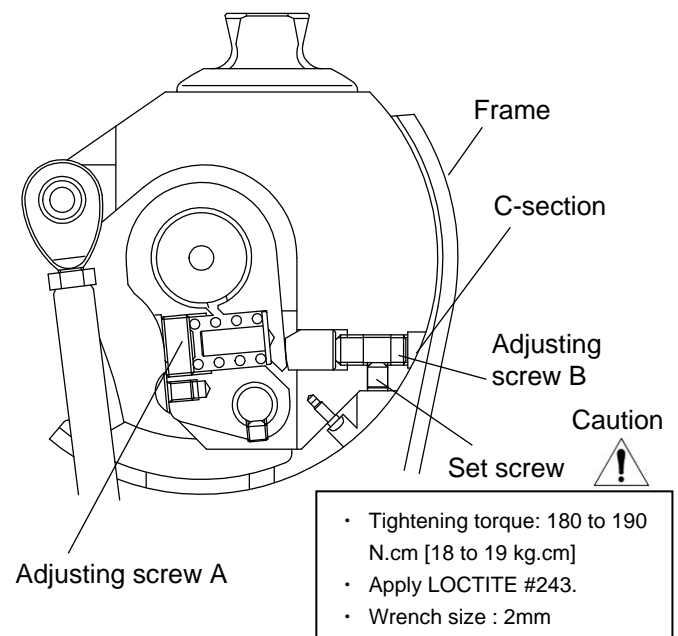

Figure 2 Construction of load brake

2. Replacement procedure of rubber extension stops

Replace the rubber extension stops in accordance with the following procedure.

- 1) Bend the knee unit fully to expose the three removable set screws.
- 2) Remove the knee cover.
- 3) The rubber extension stops should now be visible and may be removed with a slotted screwdriver or similar tool.
- 4) Replace with new extension stops.
- 5) Secure the knee cover using the three set screws. Apply adhesive(LOCTITE # 243 or equivalent) to the set screws.
- 6) Confirm correct operation by bending and extending the knee unit.

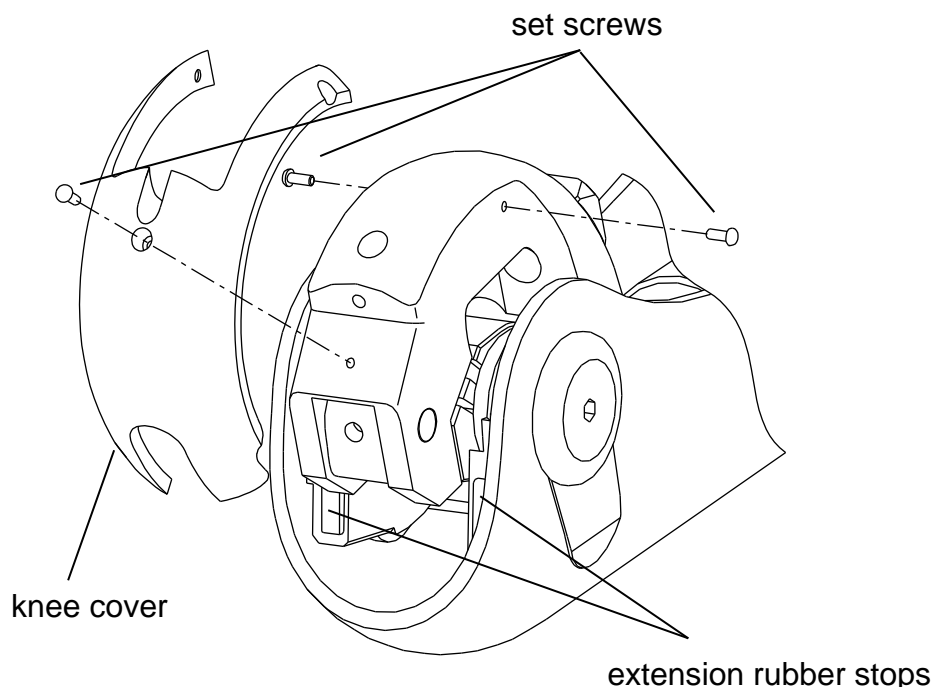

Figure 3. Replacement of rubber extension stops

3. Adjustment when looseness occurs in the knee axis

Adjustment to correct looseness in the knee axis

When looseness occurs in the knee axis, it can be corrected by following the adjustment procedure to tighten the knee axis screws shown in Figure 4.

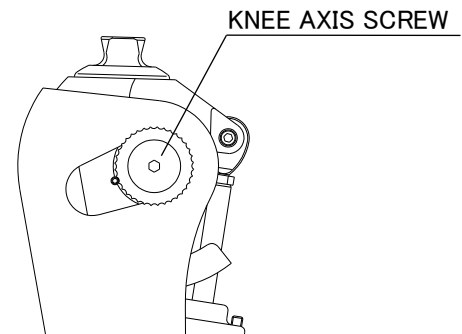

Fig.4

Adjustment procedure

1. In order to provide a reference for the degree of knee axis screw tightening, apply a mark (using magic ink for example) on the root thread of the knee axis screw which is in contact with the locking screw. (See Figure 5.)

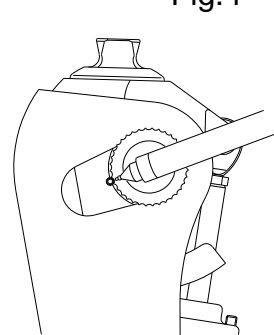

Fig.5

2. Remove the locking screw using a hexagonal wrench (1.5mm). (See Figure 6.)

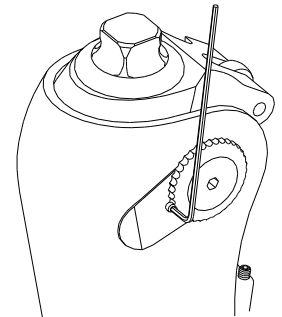

Fig.6

3. Using a hexagonal wrench (4mm), tighten the knee axis screw a single thread and check for looseness. If still loose, repeat the knee axis screw tightening procedure. However, be aware that over-tightening will cause an increased resistance to bending and extending motion. (See Figure 7)

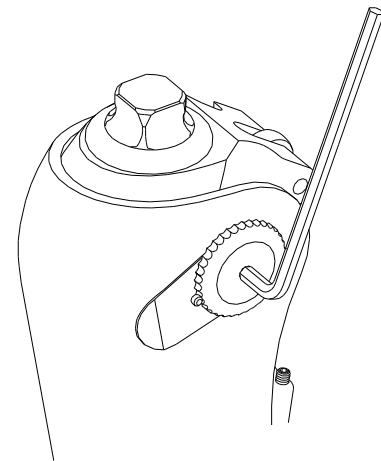

Fig.7

4. Confirm smoothness by bending and extending the knee, then set the locking screw. (See Figure 8.)

(Caution) Adhesive (LOCTITE #243 or equivalent) must be applied to the set screw to prevent loosening.

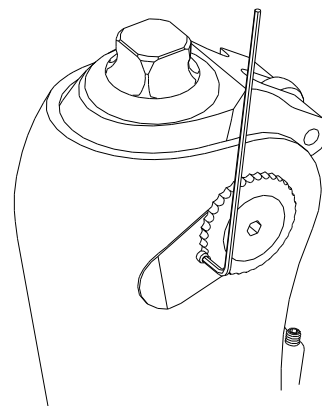

Fig.8

4. Battery replacement procedure



Before inserting the battery connector, be sure to eliminate static electricity by, for example, touching a desk.

1. Remove the battery connector off the circuit board.
(See Fig.9.)
2. Loosen the outer clamp tightening bolt, then pull out the pipe.
3. Remove the outer clamp off the frame, remove the locking screw, then pull out the inner clamp together with battery case. (See Fig.10.)
4. Turn the cap of battery holder using a coin or the like then remove the battery. (See Fig.11.)

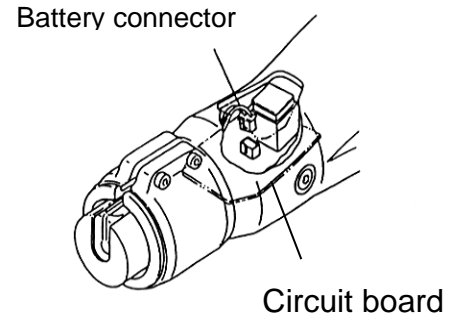

Fig.9 Removing the battery

5. Place new battery in the battery holder.
* In placing the new battery, have the battery lead wire be in the slit on the inner clamp.
(Otherwise, the battery will not go fully into depth.)
(See Fig.12.)

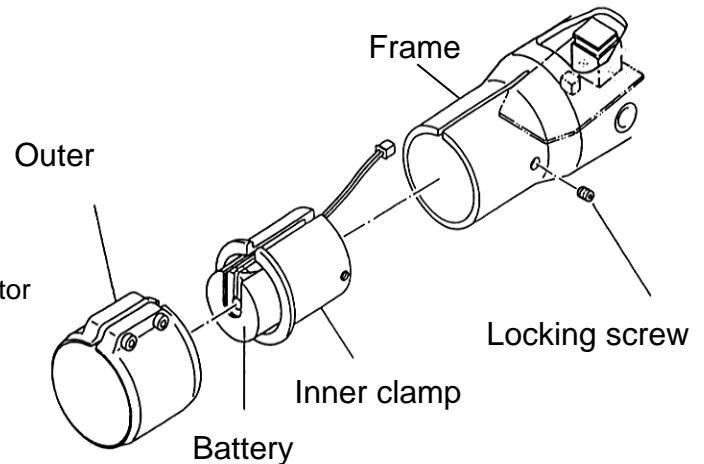

Fig.10 Removing the clamp

6. Set the cap of battery holder, then fix it.
7. Set the inner clamp in the frame.
* In setting the inner clamp, have the battery connector be on the front surface side of the circuit board, as shown in Fig.10.
8. Set the locking screw.
* Drive the screw to the extent that the screw head is not projecting out the frame surface.
Be aware particularly that an over-driving may cause damage to battery case and battery itself.

9. Set the outer clamp in place.

10. Plug the battery connector in the connector on the circuit board.
* In plugging in the connector, use of tweezers will make the job easier.

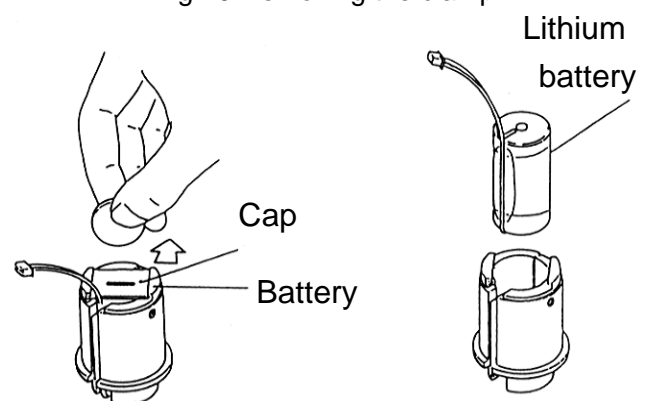
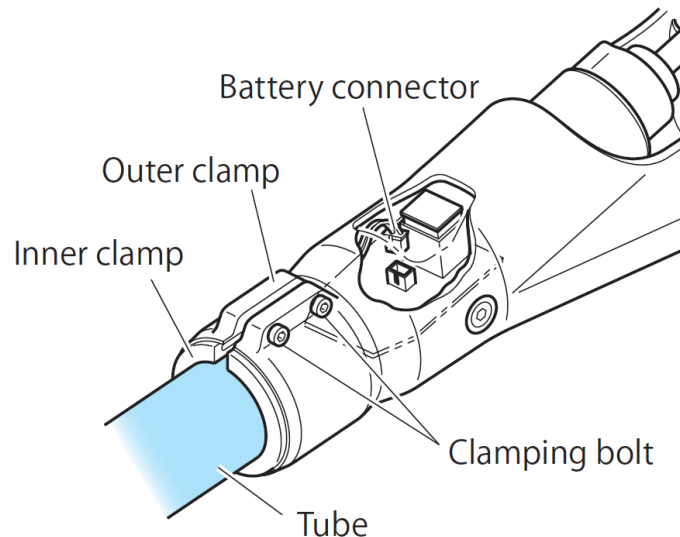

Fig.11 Removing the battery cap

Fig.12 Removing the battery

5. Assembling the Tube

- 1 Loosening the outer clamp bolts, insert the tube into the inner clamp and push the tube until it hits the stopper of the inner clamp.
- 2 When assembling the tube, be sure to align the split groove of the outer clamp with that of the inner clamp.
- 3 Tighten the bolts to a torque of 4.5 to 5.0 N·m.



For safe use, you are recommended to use the tube made by Nabtesco. When using one made by any other manufacturer due to unavoidable circumstances, be sure to use one whose outside dimension tolerance is within ± 0.05 mm.

6. Inserting the Battery Connector



Before inserting the battery connector, be sure to eliminate static electricity by, for example, touching a desk.

The battery connector has been disconnected for shipment. To use the Knee Joint, be sure to insert the battery connector into the circuit board connector.

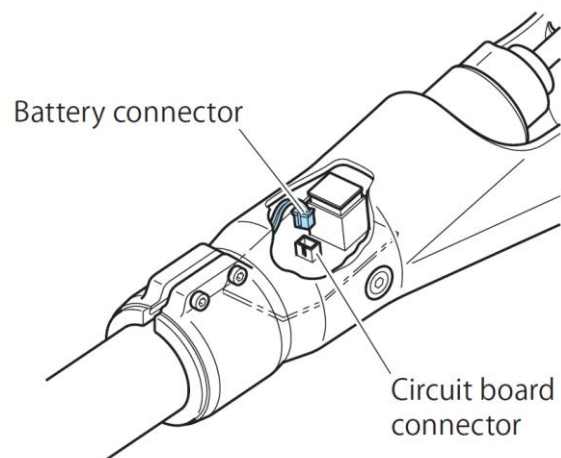

- Connecting the adjustment unit, perform reset.
- Confirm that motor sound is normal.
- * When the motor continues to run, perform the reset operation. (There is a risk that battery electricity may be abnormally consumed.)